

RF AMPLIFIER FOR CATV TUNER
N-CHANNEL Si DUAL GATE MOS FIELD-EFFECT TRANSISTOR
4 PINS SUPER MINI MOLD

FEATURES

- Low V_{DD} Use : ($V_{DS} = 3.5\text{ V}$)
- Driving Battery
- Low Noise Figure : $NF1 = 2.0\text{ dB TYP. (}f = 470\text{ MHz)}$
 $NF2 = 0.8\text{ dB TYP. (}f = 55\text{ MHz)}$
- High Power Gain : $G_{PS} = 19.0\text{ dB TYP. (}f = 470\text{ MHz)}$
- Suitable for use as RF amplifier in CATV tuner.
- Automatically Mounting : Embossed Type Taping
- Small Package : 4 Pins Super Mini Mold

ABSOLUTE MAXIMUM RATINGS ($T_A = 25\text{ }^\circ\text{C}$)

Drain to Source Voltage	V_{DSX}	18	V
Gate1 to Source Voltage	V_{G1S}	$\pm 8^{*1}$	V
Gate2 to Source Voltage	V_{G2S}	$\pm 8^{*1}$	V
Gate1 to Drain Voltage	V_{G1D}	18	V
Gate2 to Drain Voltage	V_{G2D}	18	V
Drain Current	I_D	25	mA
Total Power Dissipation	P_D	130^{*2}	mW
Channel Temperature	T_{ch}	125	$^\circ\text{C}$
Storage Temperature	T_{stg}	-55 to +125	$^\circ\text{C}$

*1: $R_L \geq 10\text{ k}\Omega$

*2: Free air

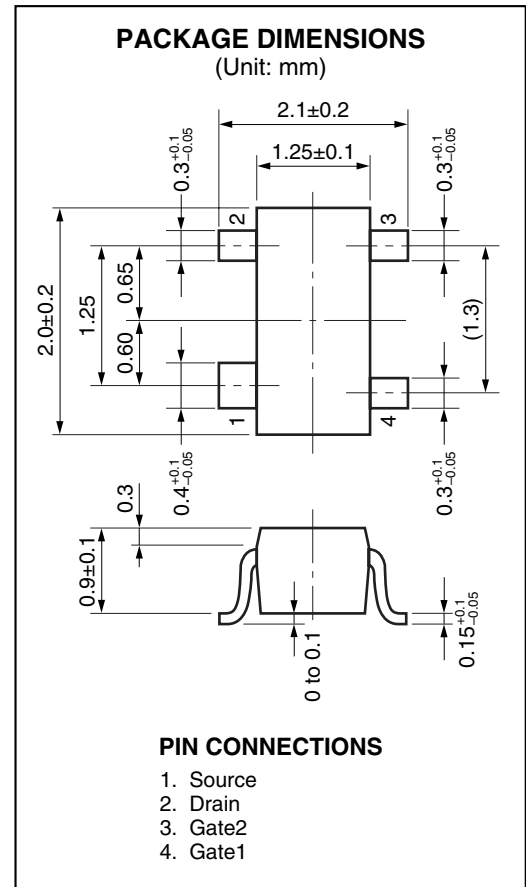

PRECAUTION:

Avoid high static voltages or electric fields so that this device would not suffer from any damage due to those voltage or fields.

The information in this document is subject to change without notice. Before using this document, please confirm that this is the latest version.
 Not all devices/types available in every country. Please check with local NEC Compound Semiconductor Devices representative for availability and additional information.

ELECTRICAL CHARACTERISTICS (T_A = 25 °C)

CHARACTERISTIC	SYMBOL	MIN.	TYP.	MAX.	UNIT	TEST CONDITIONS
Drain to Source Breakdown Voltage	BV _{DSX}	18			V	V _{G1S} = V _{G2S} = -2 V, I _D = 10 μA
Drain Current	I _{DSX}	0.1		5.0	mA	V _{DS} = 3.5 V, V _{G2S} = 3 V, V _{G1S} = 0.5 V
Gate1 to Source Cutoff Voltage	V _{G1S(off)}	-1.0	0	+1.0	V	V _{DS} = 3.5 V, V _{G2S} = 3 V, I _D = 10 μA
Gate2 to Source Cutoff Voltage	V _{G2S(off)}	0	0.5	1.0	V	V _{DS} = 3.5 V, V _{G1S} = 3 V, I _D = 10 μA
Gate1 Reverse Current	I _{G1SS}			±20	nA	V _{DS} = 0, V _{G2S} = 0, V _{G1S} = ±6 V
Gate2 Reverse Current	I _{G2SS}			±20	nA	V _{DS} = 0, V _{G1S} = 0, V _{G2S} = ±6 V
Forward Transfer Admittance	Y _{fs1}	14	18	23	mS	V _{DS} = 3.5 V, V _{G2S} = 3 V, I _D = 7 mA f = 1 kHz
Input Capacitance	C _{iss}	2.4	2.9	3.4	pF	V _{DS} = 3.5 V, V _{G2S} = 3 V, I _D = 7 mA f = 1 MHz
Output Capacitance	C _{oss}	0.9	1.2	1.5	pF	
Reverse Transfer Capacitance	C _{rss}		0.01	0.03	pF	
Power Gain	G _{ps}	16	19	22	dB	V _{DS} = 3.5 V, V _{G2S} = 3 V, I _D = 7 mA
Noise Figure 1	NF1		2.0	3.0	dB	f = 470 MHz
Noise Figure 2	NF2		0.8	2.3	dB	V _{DS} = 3.5 V, V _{G2S} = 3 V, I _D = 7 mA f = 55 MHz

I_{DSX} Classification

Rank	U1E
Marking	U1E
I _{DSX} (mA)	0.1 to 5.0

★

TYPICAL CHARACTERISTICS (T_A = 25 °C)

TOTAL POWER DISSIPATION vs. AMBIENT TEMPERATURE

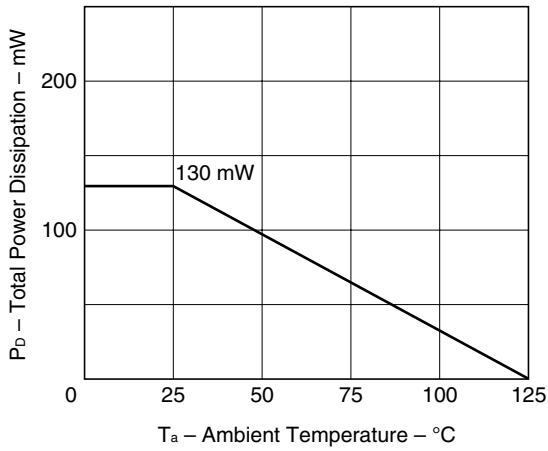

DRAIN CURRENT vs. DRAIN TO SOURCE VOLTAGE

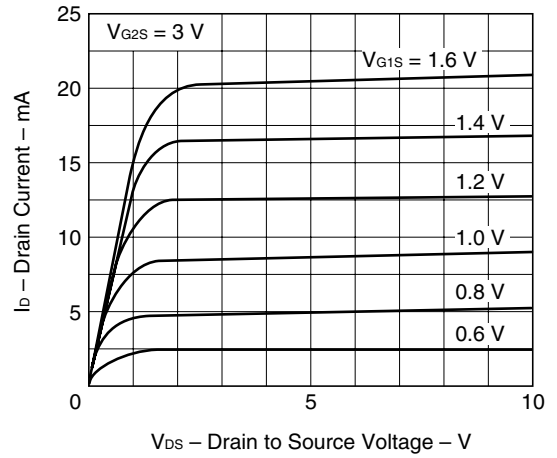

DRAIN CURRENT vs. GATE1 TO SOURCE VOLTAGE

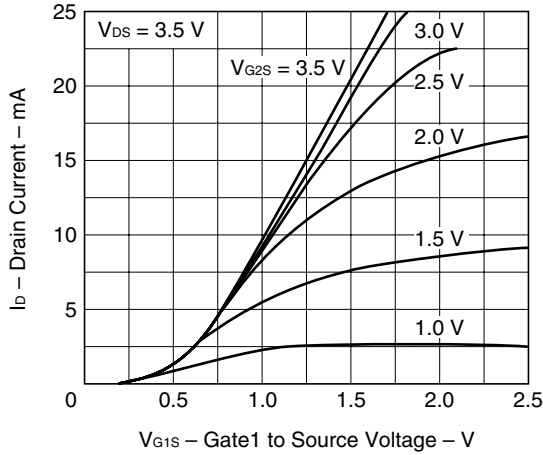

FORWARD TRANSFER ADMITTANCE vs. GATE1 TO SOURCE VOLTAGE

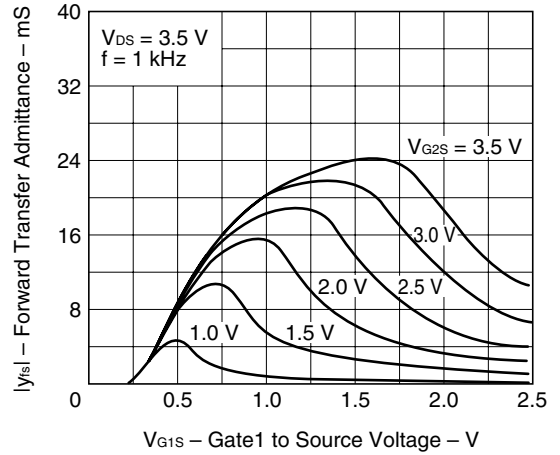

FORWARD TRANSFER ADMITTANCE vs. DRAIN CURRENT

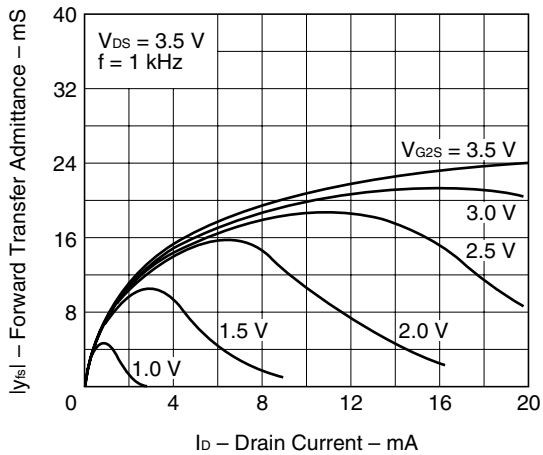

INPUT CAPACITANCE vs. GATE2 TO SOURCE VOLTAGE

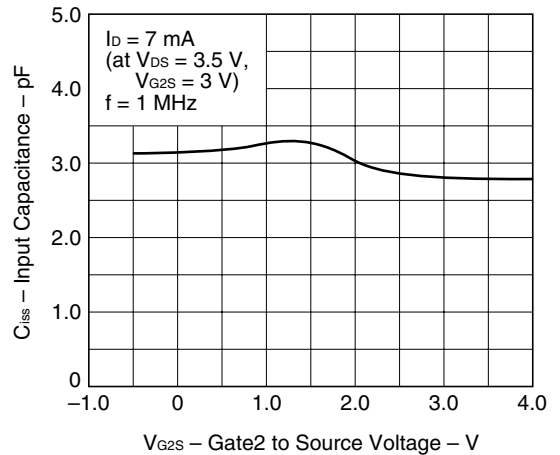

OUTPUT CAPACITANCE vs.
GATE2 TO SOURCE VOLTAGE

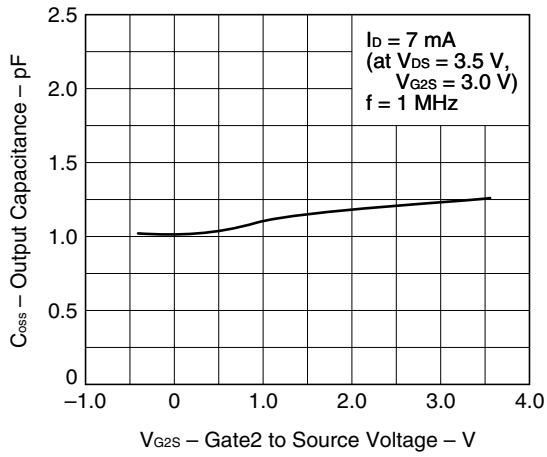

POWER GAIN AND NOISE FIGURE vs.
GATE2 TO SOURCE VOLTAGE

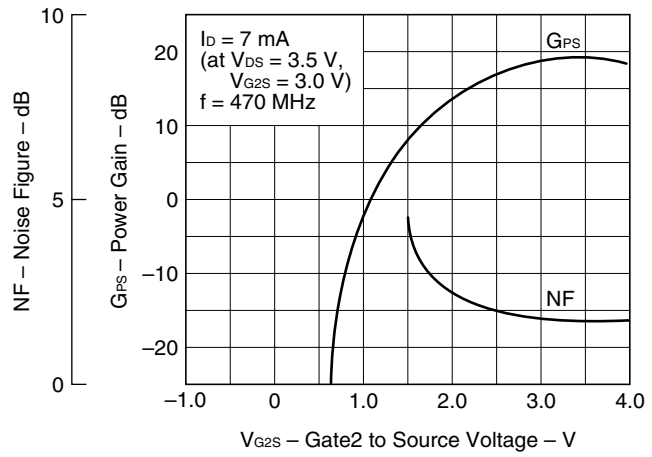

GPS AND NF TEST CIRCUIT AT $f = 470 \text{ MHz}$

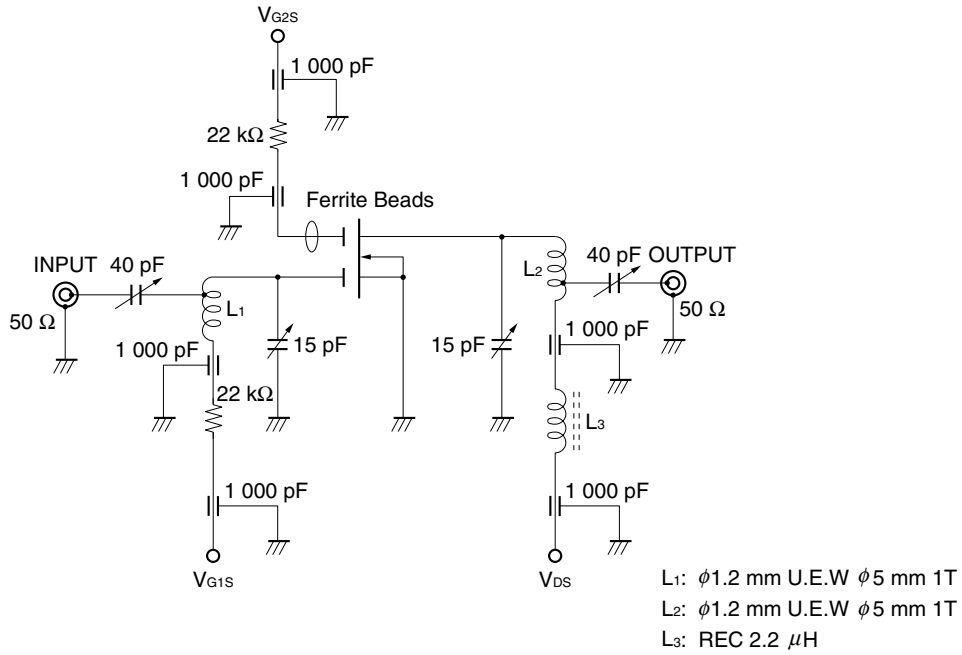

NF TEST CIRCUIT AT $f = 55 \text{ MHz}$

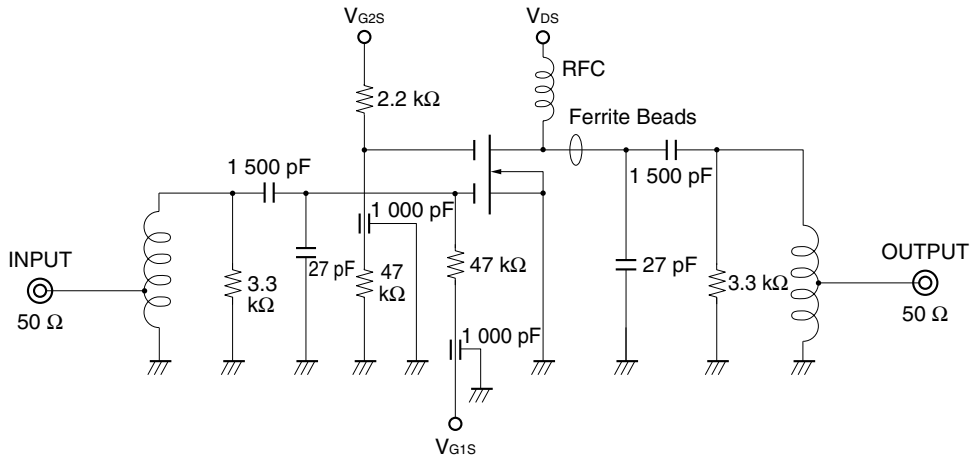

- **The information in this document is current as of October, 2001. The information is subject to change without notice. For actual design-in, refer to the latest publications of NEC's data sheets or data books, etc., for the most up-to-date specifications of NEC semiconductor products. Not all products and/or types are available in every country. Please check with an NEC sales representative for availability and additional information.**
 - No part of this document may be copied or reproduced in any form or by any means without prior written consent of NEC. NEC assumes no responsibility for any errors that may appear in this document.
 - NEC does not assume any liability for infringement of patents, copyrights or other intellectual property rights of third parties by or arising from the use of NEC semiconductor products listed in this document or any other liability arising from the use of such products. No license, express, implied or otherwise, is granted under any patents, copyrights or other intellectual property rights of NEC or others.
 - Descriptions of circuits, software and other related information in this document are provided for illustrative purposes in semiconductor product operation and application examples. The incorporation of these circuits, software and information in the design of customer's equipment shall be done under the full responsibility of customer. NEC assumes no responsibility for any losses incurred by customers or third parties arising from the use of these circuits, software and information.
 - While NEC endeavours to enhance the quality, reliability and safety of NEC semiconductor products, customers agree and acknowledge that the possibility of defects thereof cannot be eliminated entirely. To minimize risks of damage to property or injury (including death) to persons arising from defects in NEC semiconductor products, customers must incorporate sufficient safety measures in their design, such as redundancy, fire-containment, and anti-failure features.
 - NEC semiconductor products are classified into the following three quality grades:
 "Standard", "Special" and "Specific". The "Specific" quality grade applies only to semiconductor products developed based on a customer-designated "quality assurance program" for a specific application. The recommended applications of a semiconductor product depend on its quality grade, as indicated below. Customers must check the quality grade of each semiconductor product before using it in a particular application.
 "Standard": Computers, office equipment, communications equipment, test and measurement equipment, audio and visual equipment, home electronic appliances, machine tools, personal electronic equipment and industrial robots
 "Special": Transportation equipment (automobiles, trains, ships, etc.), traffic control systems, anti-disaster systems, anti-crime systems, safety equipment and medical equipment (not specifically designed for life support)
 "Specific": Aircraft, aerospace equipment, submersible repeaters, nuclear reactor control systems, life support systems and medical equipment for life support, etc.
- The quality grade of NEC semiconductor products is "Standard" unless otherwise expressly specified in NEC's data sheets or data books, etc. If customers wish to use NEC semiconductor products in applications not intended by NEC, they must contact an NEC sales representative in advance to determine NEC's willingness to support a given application.
- (Note)
- (1) "NEC" as used in this statement means NEC Corporation, NEC Compound Semiconductor Devices, Ltd. and also includes its majority-owned subsidiaries.
 - (2) "NEC semiconductor products" means any semiconductor product developed or manufactured by or for NEC (as defined above).

M8E 00.4-0110

► **Business issue**

NEC Compound Semiconductor Devices, Ltd.

5th Sales Group, Sales Division TEL: +81-3-3798-6372 FAX: +81-3-3798-6783 E-mail: salesinfo@csd-nec.com

NEC Compound Semiconductor Devices Hong Kong Limited

Hong Kong Head Office TEL: +852-3107-7303 FAX: +852-3107-7309

Taipei Branch Office TEL: +886-2-8712-0478 FAX: +886-2-2545-3859

Korea Branch Office TEL: +82-2-528-0301 FAX: +82-2-528-0302

NEC Electron Devices European Operations <http://www.nec.de/>

TEL: +49-211-6503-101 FAX: +49-211-6503-487

California Eastern Laboratories, Inc. <http://www.cel.com/>

TEL: +1-408-988-3500 FAX: +1-408-988-0279

► **Technical issue**

NEC Compound Semiconductor Devices, Ltd. <http://www.csd-nec.com/>

Sales Engineering Group, Sales Division

E-mail: techinfo@csd-nec.com FAX: +81-44-435-1918